



# APBA

AFRICA PRINTING AND BRANDING AGENCY

*“Empowering Businesses to Make Their Mark”*



## top selling products

product & services catalog

[www.apbagency.co.za](http://www.apbagency.co.za)

## Choose the Right Printing & Branding Agency for Your Business

---



With our 15 years experience in printing, design and branding, we help Business Owners to overcome their Printing & Branding Challenges, as a printing and branding agency we employ various techniques and strategies to help clients achieve their print and branding projects goals.

We will optimize your printing projects by streamlining design elements, selecting cost-effective quality stocks, and exploring efficient printing techniques. This ensures that our clients achieve the desired results while maximizing their investment.

APB Agency is a specialized field that plays a crucial role in the success of businesses across Africa. As a printing & Branding Agency, my primary objective is to help clients optimize their printing & branding projects processes to achieve their marketing and communication goals.

By leveraging my expertise in print production, design, branding and technology, I provide valuable insights and recommendations that drive cost savings, efficiency, and overall effectiveness





# index

---

stationery	4
letterheads & envelopes	5
business cards	6
postcards	7
brochures	8
flyers	9
booklets	10
presentation folders	11
notepads	12
pens	13
promotional products	14
apparel	15
forms & carbonless	16
stamps & catalogs	17
direct mail & EDDM	18
variable data	19
plaques & awards	20
door hangers	21
rack cards	22
labels & stickers	23
magnets	24
signage	25
large format & posters	26
banners & pull up banners	27
checks & tickets	28
menus & table tents	29
greeting cards & invitations	30
calendars & planners	31

Additional options are available; the tables in this catalog show the most common sizes, stocks, and finishes.

# creative design

A great design communicates what your business is, what it does, and why customers should choose you. Our designers take the time to understand and assist you with everything from a logo design to a high-end brochure.

Collection ideas and designs you like is the first step in helping us bring your vision to life. We can build you a company image that is professional and stylish.

# stationery

Give your correspondence some added class by having your stationery and envelopes designed and printed by our professional staff. Whether you're writing a letter to a business acquaintance or a personal note to a close friend, our helpful and professional staff will help you select the concept, design, and paper. If you need a simple, one-color design or multi-color printing with foil embossing, we'll deliver a product you will be proud to use.

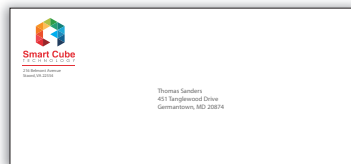

# letterheads

Along with your business cards, your letterheads are an important piece in your office stationary. Whether you're sending a business letter, proposal, or invoice, your letterhead is the face of your business.

size	color	stock	weight
8.5" x 11"	full color Pantone®	uncoated	24 lb.



# envelopes

Branded envelopes will give your company a professional look when coordinated with letterheads.

size	style	face	closure
#6 3/4	booklet	plain	peel-n-seal
#10	catalog	window	simple seal
10" x 13"	remittance return security		moist seal

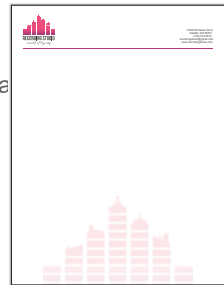

# business cards

A first impression lasts, Quality business cards are essential to anyone looking to promote a professional identity. Our full-color, high-quality printing technologies allow us to provide you with a business cards you can be proud of. We offer a wide variety of designs, colors, paper stock and finishes that will surly fit your needs.

Your business cards directly reflects your company. Don't put potential partners or customers to sleep with plain paper and dull designs. Let Apb Agency produce high quality, full color cards that are sure to grab attention long after an introduction!

size	color	# of sides	stock	weight	laminating	options
3.5" x 2"	full color	one-sided	coated gloss	80 lb.	glossy	spot uv
fold over	black & white	two-sided	coated matte	100 lb.	matte	raised print
custom	Pantone®		uncoated specialty	120 lb.		die cut embossed foil stamped

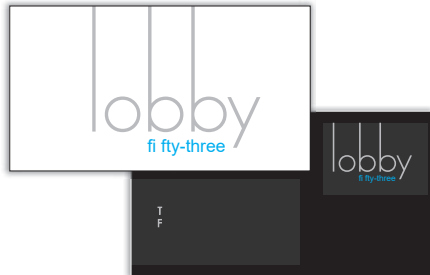

# postcards

Postcards are an inexpensive and effective way to promote your business. With a bold, colorful design they can be very informative and deliver a direct message without a lot of text. Their size makes them easy to transport and they can be used for trade shows, mail-out campaigns, and countertop give-away items.

Postcards can even use variable data, allowing you to personalize material according to your individual customer. Variable data allows you to change text, graphics, and images from one printed piece to the next, using information sourced from a database or another external file

size	color	# of sides	stock	weight	laminating	options
3" x 5"	full color	one-sided	coated gloss	80 lb.	glossy	spot uv
4" x 6"	black & white	two-sided	coated matte	100 lb.	matte	laminate
5" x 7"	Pantone®		uncoated	120 lb.		
custom						



# brochures

A well-designed brochure sells your product. It can excite and entice a consumer to find out more about the promotion. To work, it needs to be graphically appealing and carefully scripted. It also needs to be expertly printed and finished to do its job correctly. Think of Apb Agency as your marketing partner in business. Let us help you produce and distribute a brochure so that it can help promote your product and increase your overall sales.

size	color	format	stock	weight	laminating	options
5.5" x 8.5"	full color	portrait	coated gloss	28 lb.	glossy	spot uv
8.5" x 11"	Pantone®	landscape	coated matte	60 lb.	matte	lamine
8.5" x 14"	black & white		uncoated	80 lb.		
11" x 17"				100 lb.		
custom						



# flyers

A flyer should grab the attention of a potential customer. The design and message need to be clear and enticing to gain the prospective buyer's interest. Our +15 years of experience will help you promote your products and your company. We print on all paper stocks, from lightweight inexpensive to high-quality premium papers and cards stock. We also offer multiple options to professionally finish your project. Flyers have always been a great form of communication, especially when created and produced by our professional staff.

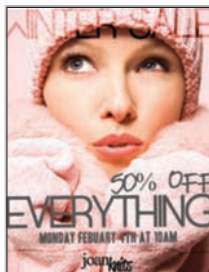

size	color	# of sides	stock	weight
8.5" x 11"	full color	one-sided	coated gloss	28 lb.
8.5" x 14"	Pantone®	two-sided	coated matte	60 lb.
11" x 17"	black and white		uncoated	80 lb.
custom			cover	100 lb.

# folding options

every need:

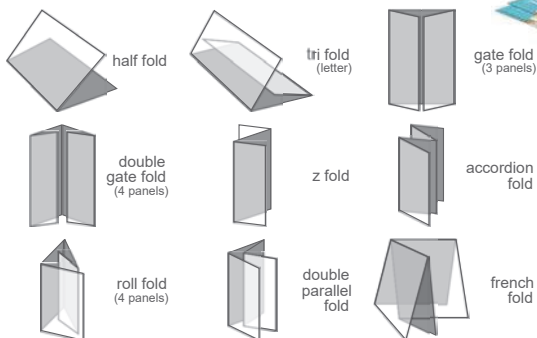



# booklets

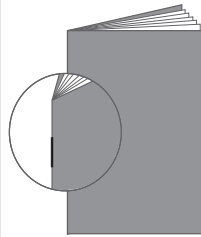

This booklet is an example of a saddle-stitched booklet. This technique uses two staples along the spine to bind it. This binding can be used to make self-covered booklets, in which the cover and contents are on the same stock; it can also make a plus cover booklet, where the cover is on thicker stock.

# coil bound

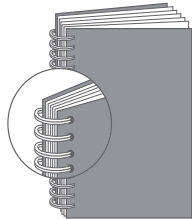
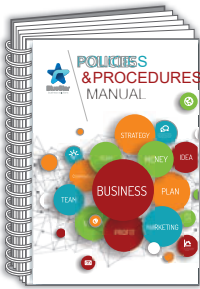

Coil-bound booklets are punched along the left side, then a twin loop wire or plastic coil is inserted through the holes and closed. This design enables the booklet to lay flat and the pages can rotate 360°. These booklets have a clear plastic front cover and thicker back cover, making them durable.

# perfect bound

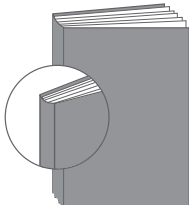

Perfect binding is widely used because it offers a professional, sophisticated look with high visual appeal. Perfect bound books are created using melted glue that is strong yet flexible, and they have a rectangular spine. This style is a popular binding method for paperback/softcover books, magazines, and catalogs.

# presentation folders

Would you walk into an important business meeting in a tank top and sandals? Impressions are all about presentation, so why not dress up your documents so they stand out professionally? If looking professional is important, then quality presentation folders are a must! They can help your odds of landing a potential client. You may produce award-winning services or products, but if they are not presented professionally, the order may be lost. Apb Agency produces folders in a wide range of shapes and sizes, and our folders are ready for any presentation you may need.

size	color	format	stock	weight	laminating	options
custom	full color Pantone®	1 pocket 2 pockets	coated gloss coated matte uncoated	80 lb. 100 lb.	glossy matte	spot uv embossed foil stamped



# notepads

Promotional products, such as note pads and desk pads, present an opportunity to achieve brand visibility with your current and prospective customers every day. If your company-branded note pad has a simple layout, great design, and a to-do list, it has the potential to be an item always found on every desk.

Desk pads are also a way to have your company seen all year at a cost-effective price. When a calendar is included in the design, it becomes an item your customers can refer to daily. Remember, don't overpower these items with your branding. If your customers aren't using them, they aren't effective marketing pieces.

size	color	# of sides	stock	weight	
3" x 3"	full color	one-sided	uncoated	20 lb.	glued
3" x 5"	black & white	two-sided		24 lb.	
5.5" x 4.25"	Pantone®			28 lb.	
5.5" x 8.5"				60 lb.	
custom					

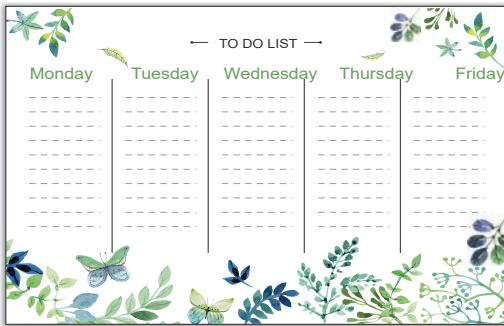

# pens

We all use pens, so they are among the most common items used for promotional marketing. Companies everywhere have seen the benefits in handing out pens, but they're more than a mere marketing giveaway. Specially designed pens can be used as corporate gifts for both employees and clients.

With hundreds of different styles and types, there is a pen suited for all occasions, from economical plastic pens to premium metal pens. Pens can be branded in different ways: single-color print, multi-color prints, engraved. Select a reliable, quality pen that is comfortable and nice to write with. You want your clients to go looking for their favorite pen if it's removed from their desk.

color	types	style	material	features
black	ballpoint	classic with cap	plastic	cushion grip
blue	felt-tipped	retractable	metal	multiple inks
red	rollerball		recycled	



# promo products

Everyone likes to get something useful for free. They will keep this product and use it. It carries your name and contact information. It's a gift that keeps on selling. Promotional products have long been a great supplement to your marketing efforts. Selecting the right product from our extensive list of pens, mugs, caps, and more provides a great return on your investment. They can be distributed at events and corporate functions. We can also assist with mailing them to your prospects.



# apparel

---

Polo shirts, t-shirts, jackets, hats, scarves, sportswear, shirts, blouses, dresses, knitwear, vests, pants, skirts, suit jackets, ties, industrial workwear, and much more...

Corporate apparel gives your team a professional and polished look. Whether it is a branded polo shirt embroidered with your company logo or a complete outfit, we can give your company that look and feel you're after. With many corporate apparel ranges to choose from, we can help put together a uniform that meets every budget, style, and job description.

Many of the apparel ranges available offer comfortable and practical pieces that suit all body shapes and sizes without compromising style or quality. They also offer hard-wearing fabrics that have been designed for the demands of some of the most rigorous working environments. It's important to select a range that your team feels comfortable and confident wearing.



# forms

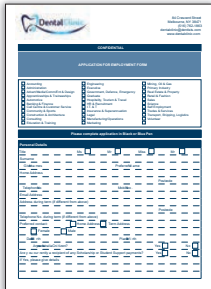

Well-designed forms can make a business run smoothly, but they are often overlooked. Having a good form to hand out to potential clients or staff members gives your company a professional and organized appearance.



Forms also assist with the workflow within the company. If filled in and filed correctly, they make locating information quick and simple. Apb Agency creates easy-to-use personalized forms to suit your professional needs and the needs of your business. We can even finish them so they can be inserted into binders for easy filing.

size	color	# of sides	stock	
8.5" x 11"	full color	one-sided	uncoated	numbered
custom	black & white Pantone®	two-sided		perforated

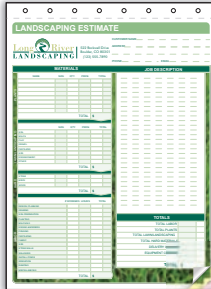

# carbonless

Quote, invoice, delivery, receipt, and purchase order books are all forms of NCR. These allow for multiple copies to be made quickly and easily when the top sheet has been filled in. These can be made up with as many carbon copies as you need. Sets within the book are on different colored stock so you can identify which copy needs to go where, or to whom.



size	color	# of copies	stock	
custom	full color black & white Pantone®	single sheet multi-part	white yellow pink blue green	stapled punched numbered perforated security guard

---

# stamps

---

Self-inking stamps are the most popular type of stamp. They're quick, convenient, and, because they have an inbuilt ink pad, mess-free. These stamps leave you with a clear impression every time. This style of stamp is available in a wide range of shapes, colors, and sizes.



---

# catalogs

---

Catalogs are usually a very detailed type of printed product that should only be produced by a professional. Apb Agency is up to the task. We can produce this all-important product in a variety of sizes and styles, with totally custom designs with functionality built into every page. Multiple binding and paper options are available.

Producing a catalog, journal, or newsletter is never an easy task, but with guidance and assistance from Apb Agency, each step of the way, you will have a product that you are proud to distribute.



# direct mail & EDDM

Direct mail is an effective way of reaching new customers. A properly run direct mail program with a strong call to action has always been a great form of advertising. Apb Agency has the equipment, experience, and expertise to help your mailing project succeed! Whether you have your own concept and design or you need assistance getting started, our team will create and design something for you. When it comes to reaching a precise group or just a specific territory, we have the data resources to handle it for you. If you already have a direct mailing list, we can take your list and incorporate it into a mailing piece for you. We use postal-approved software to save you money on your mailings.

size	color	# of sides	stock	weight	laminating	options
3" x 5"	full color	one-sided	coated gloss	80 lb.	glossy	spot uv
4" x 6"	black & white	two-sided	coated matte	100 lb.	matte	laminate
5" x 7"	Pantone®		uncoated	120 lb.		
6" x 12"						



# variable data

Did you know that using variable data can potentially increase your ROI by five to ten times over traditional direct mail campaigns? With variable data, we can customize your direct mail piece specifically to your individual customers. Let us help you reach your customers by personalizing a variable data mail piece precisely for them.

The image displays four examples of personalized direct mail cards for Jack's Auto Sales. Each card features a different car and a customer's name, demonstrating variable data. The cards are arranged in a 2x2 grid. Each card has a blue header with the text "Great News! A Special Car Just For You, [Name]" and an orange call-to-action button that says "Call us for more details!". The Jack's Auto Sales logo and address (2224 Strawberry Lane, Lorain, OH 44052) are also present on each card. The cars shown are a blue pickup truck, a black sports car, a white Volkswagen Beetle, and a white SUV.

Customer Name	Car Model	Address
Nick	Blue Pickup Truck	2224 Strawberry Lane, Lorain, OH 44052
Michael	Black Sports Car	8346 Forest Street, Altamonte Springs, FL 32714
Edward	White Volkswagen Beetle	2224 Strawberry Lane, Lorain, OH 44052
Kevin	White SUV	950 Buckingham Drive, Depew, NY 14043

# plaques & awards

Custom-made plaques and awards are the perfect way to commemorate achievements. We can create a wide variety of plaques and awards, from preserving a diploma, to honoring an accomplishment. These great gifts will last a lifetime.



# door hangers

A custom-designed door hanger should be bold, colorful, and informative. They can be an effective way to deliver your message. Our knowledgeable staff will walk you through each step, from the concept of the design to the completion of the product.

size	color	# of sides	stock	weight	options
3.5" x 8.5"	full color	one-sided	coated	80 lb.	uv coated
4.25" x 11"	black & white Pantone®	two-sided	uncoated	100 lb. 120 lb.	laminated



# rack cards

Custom-designed rack cards are a cost-effective way to promote your business. They're easy to create, extremely affordable, and make a great presentation when properly displayed.

size	color	# of sides	stock	weight	options
3.5" x 8.5"	full color black & white Pantone®	one-sided two-sided	coated uncoated	80 lb. 100 lb.	uv coated laminated



# labels & stickers

From circles to square-cut labels and ovals to gold embossed seals, we can create whatever specialty shaped stickers or labels you need. We handle them all! Whatever your product needs, Apb Agency will help you fill them. We offer a wide selection of labels and stickers for a variety of purposes available in unlimited designs.



# magnets

Magnets can be created in all sorts of shapes and sizes, and we can help you select the perfect promotional magnet for your next event or campaign. Packing a powerful marketing punch, magnets act as an eye-catching reminder of your company and its products or services.

Give customers extra incentive to keep your promotional magnet by including a calendar in its design; once placed on the fridge, everyone at home or the office can refer to it. This style is very popular with real estate agencies, while a standard 3.5" x 2" size is popular with trade services. Outdoor magnets are a great idea for a plumbing business; printed with a UV-resistant ink that will resist fading, so they can be left on the side of your heating unit.

Custom car magnets are quickly becoming popular with companies that want to increase brand awareness or improve their image. They're an inexpensive way of adding signage to your vehicles that won't damage your paint work.



# signage

Signage is one of the most important elements of your business. When done right, signs can make your business highly visible and promote your brand. Whether you're looking to make your storefront stand out or promote your business at special events, professional signage can make all the difference. Signs are also versatile and perform several necessary functions that keep your space well-organized for your customers.



# large format & posters

Posters are a great way to take your message to the masses in vibrant, eye-catching color. Available in a range of sizes, posters can be printed individually or by the hundreds. We can also laminate them for durability or mount them if they are to be on display or for a presentation.

size	color	formats	stock	laminating
12" x 16"	full color	portrait	coated gloss	gloss
18" x 24"	black & white	landscape	coated matte	matte
24" x 36"			uncoated	
custom				



36" x 48" Poster



# banners

Well-designed banners or posters used at exhibitions, special events, or trade shows can bring crowds of people to your booth. Draw attention to your promotion with big, bright, and colorful banners. Get the “wow factor” working for your business with large format banners and posters; available with a variety of finishing options

vinyl		expo displays	options
single-sided	single-sided teardrop	wall unit	grommets
double-sided	double-side teardrop	promotional table	pull pockets
mesh single sided	single-sided feather	fabric wall unit	rope
portrait	double-sided feather	brochure holder	fabric blend
landscape		snap-a-frame	
indoor		steel-a-frame	
outdoor			



# pull up banners

In the office, on the road, or wherever you may be, pull up banners are an excellent poster alternative. These freestanding units are held up by their own stand. They come with their own slimline carry bag making them totally transportable. Pull up banners are sure to attract attention and get potential customers talking.

sizes	color	stand	stock
24" 47"	full color	silver black	uncoated coated matte coated glossy fabric

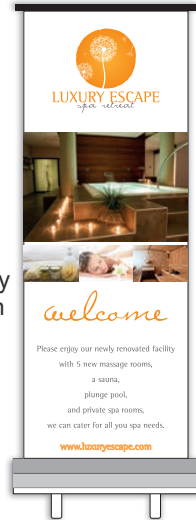

# checks



Improve your payment process as well as your business image by working with us to create your own specially printed checks. Designed with your company logo and colors, they give your business the professional distinction that many don't have. Checks give you the ability to print your check and remittance all at once.

Specially printed checks include many security features, and the numbering sequence allows you to track where checks have been sent. We can customize checks to be used easily with most software brands, including QuickBooks® and they can be printed on standard inkjet or laser printers.



# tickets

No matter the size or type, at Apb Agency, “we’ve got your ticket.” We can produce tickets for all kinds of events. Tickets can have individual numbering, perforated stubs, be printed in full color or black and white, and be finished in rolls or in books. Yes, “we’ve got your ticket!”

size	color	# of sides	stock	weight
2" x 5.5"	full color	one-sided	coated	60 lb.
2.75" x 5.5"	black & white	two-sided	uncoated	80 lb.
2.75" x 8.5"	Pantone®			100 lb.
custom				120 lb.

# menus

A properly designed and printed menu can be one of the most cost-effective and potentially profitable investments that a restaurant can make. Menus can be a tantalizing motivator, meant to attract customers to your establishment. To help create this atmosphere, you need someone with the knowledge and experience to help you produce this type of quality product. Apb Agency can do just that!



size	color	# of sides	stock	weight
8.5" x 11"	full color	one-sided	coated	60 lb.
11" x 17"	black & white	two-sided	uncoated	80 lb.
custom	Pantone®		synthetic	100 lb.



# table tents

Table tents are a great way to promote your specials or keep your customers informed about your key menu items. We can provide you with simple A-frame tents or help you create an elaborate flip display with multiple pages. Table tents are great for any type of countertop display, not just restaurants. Visit our location today and ask how we can help promote your business with a custom table tent.



size	color	# of sides	stock	weight
4" x 6"	full color	one-sided	coated	60 lb.
5" x 7"	black & white	two-sided	uncoated	80 lb.
custom	Pantone®			100 lb. 120 lb.

# greeting cards & invitations

We print custom cards for important events and holidays. We can satisfy all your greeting card needs no matter the occasion! Holiday greeting cards can be selected from some of our standard traditional styles to something completely custom designed for your company. You can add special photos, graphics, and text to your heart's content. We have the experience and know-how to help you meet your invitation and greeting card needs.

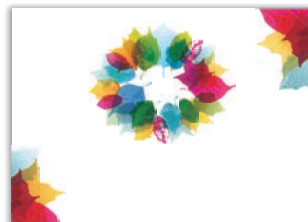
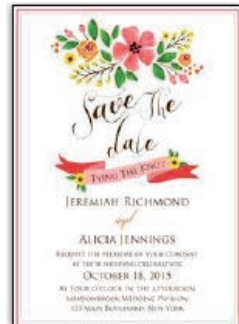

# calenders & planners

One of the most useful and effective types of printed promotional products today is the calendar because they are used daily. The purpose of a custom-printed calendar decorated with your brand identity, is to keep your name in front of your client. Your name will stay on a prospective customer's wall or desk for an entire year. In addition, you can choose to add seasonal specials to promote your business.

color	format	stock	laminating
full color	portrait	appointment	glossy
black & white	landscape	executive planner	matte
custom	planner	daily planner	
	desk	monthly planner	
	pocket	wall	

